

# TOPY 10.2 / FORD TRANSIT

TECHNICAL DATASHEET

MADE IN FRANCE



TELECOM



RENTAL COMPANIES



COMMUNITIES



PUBLICITY



DISTRIBUTORS



LIGHTING

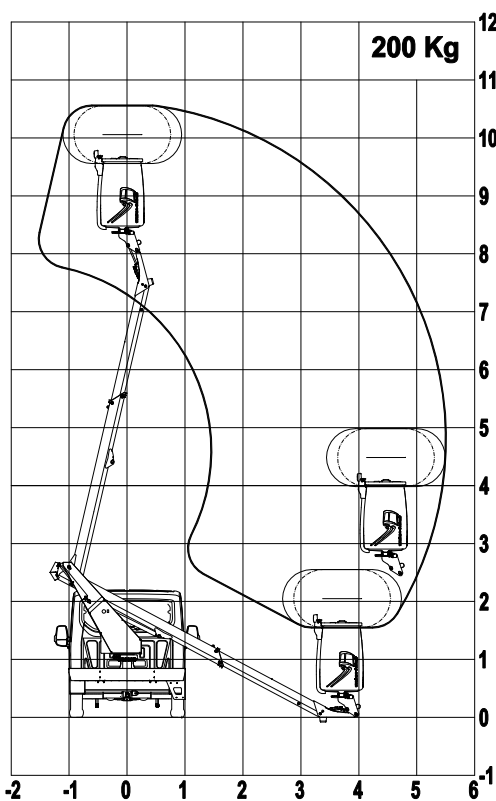

Newest generation of this iconic range, the TOPY 10.2 on FORD TRANSIT represents all the evolutions allowing a **work optimization by simplifying the use of it** recognizable for all models in the field and for multiple activities.

The basket charge of 200 Kg for two people further improves its performance.

**Reliability and budget friendly** are the foundations of this new TOPY 10.2.

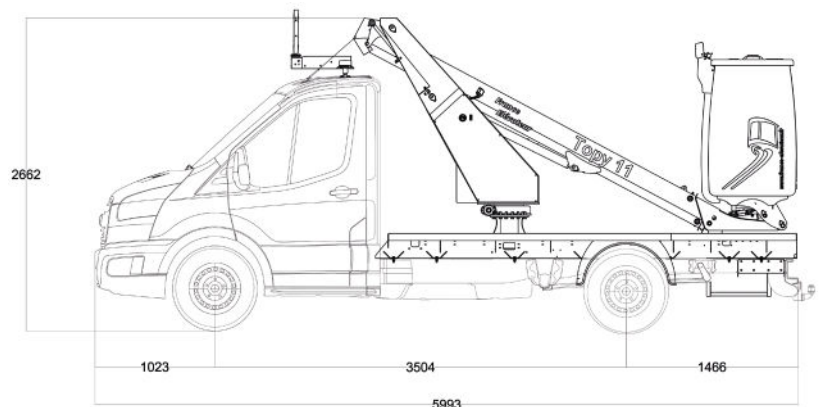

# TECHNICAL CHARACTERISTICS

As standart : ● optional : ○

Working height	10,50 m	●
Floor height	8,50 m	●
Maximum outreach without outriggers	5,50 m	●
Basket load	200 kg /2 people	●
Turret rotation	400°	●
Maximum usage tilt/slope	5% / 15%	●
1000V insulated full opening fiber basket	1300 x 780 x 1150 mm	●
GVW	3 500 kg	●
Steel boom with 1 telescopic element		●
Cable chain holder inside the telescope		●
Priority electro-hydraulic lower panel		●
Hydraulic energy by electric pump unit		●
Manual emergency pump		●
Time counter		●
Return to road position light in the cabin		●

## EQUIPEMENT

Engine start and stop in the basket		○
Auxiliary battery (depending on the vehicle)		○
2 outriggers (depending on vehicle)		○
Electric backup pump		○
BT 200 (included BT200 full basket door + backup generator)		○
boom / turret insulation 1000 V		○
230 V plug and differential protection in the basket		○
Converter 12Vdc-230 Vac - 2 kVA		○
Ladder support on tool boxes		○
Signal cone support		○
Support for traffic signs		○
Removable and adjustable working light LED 12 Vdc		○
Tool boxes		○
Aluminum skirts on the flatbed		○
Coupling hook (according to GVW)		○
2 LED flash lights + triffash + retro-reflective markup CI 1		○
Flashing light under the basket		○
Reversing camera		○
Maintenance contract		○

updated : 04/2022

Non contractual document. France Elevateur SAS reserves the right to modify the characteristics of the machines

TOPY 10.2 / FORD TRANSIT



ZAC DU PLATEAU  
54630 FLAVIGNY SUR MOSELLE - FRANCE

Phone: +33 (0)3 83 23 31 32

commercial@france-eleveur.fr | www.france-eleveur.fr

SERVICE AGENCY

### BORDEAUX

33450 Montussan  
☎ +33 (0)5 56 89 90 72

### PARIS SOUTH

91220 Brétigny sur Orge  
☎ +33 (0)1 60 85 14 23

### LAVAL

53000 Laval  
☎ +33 (0)2 43 49 07 28

### MARSEILLE

13300 Salon de Provence  
☎ +33 (0)4 90 59 36 27

### LENS

62970 Courcelles les Lens  
☎ +33 (0)3 21 79 32 15

### BENELUX

7522 Marquain  
☎ +32 (0)56 51 40 26

### PARIS WEST

95310 St-Ouen l'Aumône  
☎ +33 (0)1 39 22 12 12

### TOULOUSE

31770 Colomiers  
☎ +33 (0)5 34 35 83 50

### LYON

69800 Saint-Priest  
☎ +33 (0)4 37 25 33 90

### NANTES

44220 Couëron  
☎ +33 (0)2 40 57 02 83

### CLERMONT-FERRAND

63050 Clermont-Ferrand  
☎ +33 (0)4 73 84 23 22

### GERMANY

04179 Leipzig  
☎ +49 (0)341/30 88 95-0